

PREPARED FOR SAFETY RESEARCH & STRATEGIES, INC.

# Toyota Electronic Throttle Control Investigation

---

## Preliminary Report

David W. Gilbert, Ph.D.

Omar Trinidad

2/21/2010

This preliminary research study report outlines the procedures and partial data collected from the investigation of the circuit malfunction detection capabilities of four Toyota Electronic Throttle Controlled vehicles.

Preliminary Report

## Introduction

Historically, vehicle engine speed was mechanically controlled by use of a linkage or cable to the throttle valve assembly. The introduction of computerized engine controls has given vehicle engineers the added capability to electrically control fuel delivery, ignition, and most recently the throttle valve. By providing electrical throttle control through the means of an on-board vehicle computer, or Electronic Control Module (ECM), a number of engineering advantages were realized. Vehicle manufacturers were able to increase vehicle stability, achieve better fuel economy, reduce emissions, and eliminate components such as cruise control. One of the downside trade-offs for these beneficial performance advantages, was increased electrical and electronic complexity. Vehicle manufacturers clearly recognized the important requirement for ETC systems to perform exactly as they intended. A failure of the electrical circuits, sensors, wiring, or actuators could potentially result in a runaway engine. Electronic Throttle Control (ETC) systems needed the added redundancy of certain sensors and electrical circuits to ensure safe and reliable operation. In addition, the ECM's were programmed to detect operational abnormalities or defects in ETC components and their related electrical circuits. The intent was to build an ETC system that would always "fail-safe" in the event of potential problem.

Vehicle engineers also needed to build in driver warning capability for ETC systems. In the event that a vital ETC component or electrical circuit defect has been detected, the Malfunction Indicator Lamp (MIL) is illuminated to inform the vehicle operator of a problem. At the same time, to aid in vehicle diagnostics and repair, a Diagnostic Trouble Code (DTC) will have been recorded in the ECM memory. Each possible DTC has an identifying alpha-numeric code to aid vehicle repair of computer associated components. The recorded DTC, along with a "freeze-frame" of captured vehicle data, could be retrieved later by technicians using a diagnostic scan tool. Depending on the seriousness of the ETC malfunction, the ECM will typically have been preprogrammed to operate the engine with limited RPM or substantially reduced power. In the event that mechanical components in the throttle body were to fail, the ECM has

the added fail-safe capability to cut-off fuel delivery to limit engine speed. In the most serious cases of component failure, the ECM's fail-safe strategy could have the engine speed reduced to idle. This reduced power mode of operation would remain in the vehicle until proper repairs are made. All of these ETC fail-safe strategies were logically put in place to keep the vehicle safe and driver controllable at all times. However, for fail-safe vehicle operation, the ECM must have the programmed ability to detect a number of potential ETC malfunctions.

The ECM, in addition to operating the engine for optimum performance and emissions, is constantly monitoring sensors and circuits for incorrect or illogical values. Current production vehicles are required to meet standards for the second generation of On-Board Diagnostics (OBD II). An OBD II vehicle runs self-tests or monitors of the ECM circuitry that are typically classified as one or two trip faults. If a sensor or output circuit was to exceed the ECM's programmed threshold values, the computer should set a DTC. However, depending on the component being monitored, a MIL may not illuminate until the ECM sees the component fail a second time. Two trip fault detection logic is used for less definitive and less serious failures that are not easily distinguished as a problem area. One trip fault detection logic is used for more serious or readily identifiable problems. One trip fault monitors will set a DTC and turn on the MIL after only one instance of detection. Typically, one trip faults include electrical component, electrical circuit malfunctions, detected values that could cause engine damage, or potential safety concerns. Properly operating ETC system circuits and components are vital to safe vehicle operation. All DTC's for Toyota's ETC systems are identified in the service literature as "1 trip detection logic" with ECM code setting ability within seconds of circuit fault detection.

## **Purpose of the Study**

The purpose of this research study was to contribute to a better understanding of electronic throttle control system malfunctions and the fail-safe detection capabilities of selected vehicles equipped with electronic throttle controls. More specifically, this research primarily examined the fail-safe detection capabilities of electrical circuitry designed to prevent sudden or unintended acceleration of electronic throttle controlled vehicles manufactured by Toyota Motor Co. The Accelerator Pedal Position (APP) sensor was identified in the review of manufacturers' service literature as a significantly important ETC input for all vehicles used in the study. Since vehicle driver demands are electrically conveyed through this high priority sensor, basic testing was focused on the APP sensor, voltages, and associated wiring circuits. A secondary purpose was to identify areas of further research of ETC fail-safe detection capabilities of Toyota Motor Co. vehicles and other manufactured brands of vehicles. This limited analysis attempted to identify and characterize potential safety concerns of Toyota Motor Co. vehicles, as well as other vehicle manufacturers using electronic throttle control systems.

## **Statement of the Problem**

What are the malfunction detection and fail-safe capabilities of Toyota vehicles equipped with electronic throttle control systems?

## **Research Questions**

This research study attempts to answer the following questions:

1. Are the malfunction detection strategies of Toyota Electronic Throttle Control systems sufficient to identify fundamental APP sensor and/or circuit malfunctions?

- Does the possibility exist for Toyota Electronic Throttle Control systems to operate with undetected APP sensor and/or circuit malfunctions?

### Electronic Throttle Control Logic

Toyota's TIS service literature served as an obvious first means to understand the complex electrical and mechanical aspects of the ETC system. Claims of vehicle problems without stored DTC's in the ECM, suggested that a possible fail-safe detection condition may have been overlooked in the diagnostics. A thorough review of the available TIS service information for ETC system operation and diagnostics was conducted.

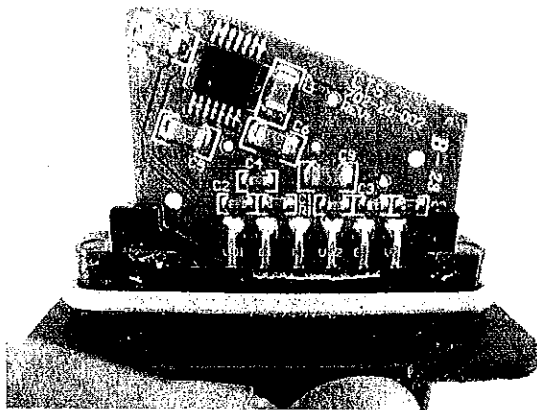

APP Sensor Circuit

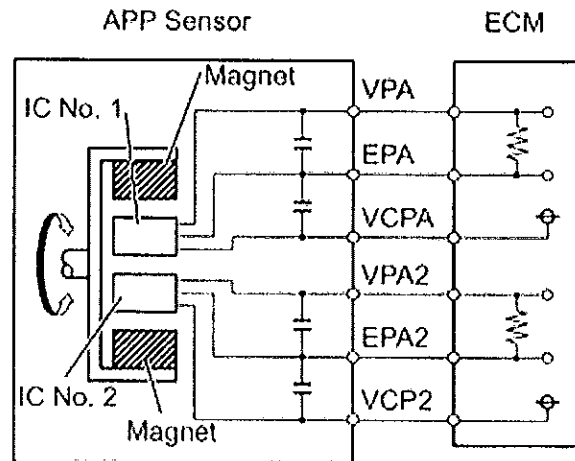

Of particular interest were the APP signal inputs to the ECM. According to the Toyota TIS service information, the APP sensor is a non-contact type that uses two independent Hall-effect elements. As described, the APP sensor will have two completely separate sensing circuits: Voltage Pedal Accelerator (VPA), and Voltage Pedal Accelerator 2 (VPA2). Each sensing circuit will have a separate voltage supply circuit (Voltage Constant Pedal, or VCP), a separate ground circuit (Earth Pedal Angle, or EPA), and separate signal circuits (VPA and VPA2). The ETC system description further defines the two signal circuits as VPA (main) and VPA2 (sub). As TIS describes the circuit, the signal from VPA (main) "indicates the actual accelerator pedal opening

angle and is used for engine control” (Appendix: TIS Service Document, p. 1). Voltage limits for VPA, range from 0.4 to 4.8 Volts or more. The signal from VPA2 (sub) “conveys the status of the circuit and is used to check the APP sensor itself” (Appendix: TIS Service Document, p. 1). Voltage limits for VPA2, range from 1.2 to 4.8 Volts or more. Of important note, are the *overlapping* voltage values of the two APP signal inputs to the ECM.

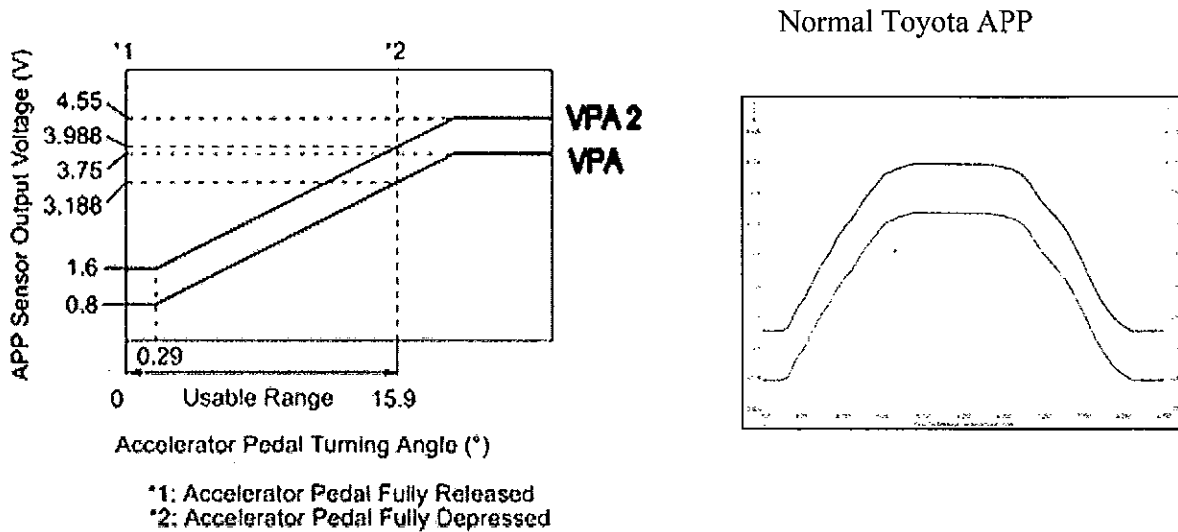

### Potential Loss of APP Sensor Redundancy

Because their important role to accurately convey vehicle driver demands for throttle opening, APP sensor voltage inputs should always be confirmable by the ECM as absolutely correct. It was noted in the service literature that the threshold limits for a voltage difference of “0.02 Volts or less” between the two APP signal circuits should set a DTC P2138 (Appendix: TIS Document, p. 3). This voltage appeared to be an unusually close threshold value for a short between circuits. In other words, these two signal voltages could have been *almost* identical, and remain safely within the parameters of the P2138 DTC threshold limits. The VPA and VPA2 normally operate through a common range of parallel planes of voltage values. In addition, the two signal voltage values are normally supposed to rise and fall in unison with each other. If the two signal voltages

were in some fashion to become interconnected (shorted) through a certain amount of circuit resistance, the lower VPA voltage could be pulled up slightly in value. The higher VPA2 voltage could be affected in the opposite manner and pulled down slightly in value. At the same time, both sensors could conceivably stay within the upper voltage boundary of 4.8 Volts or more for the P2123 and P2128 DTC criteria. Similarly, the VPA2 1.2 Volt low threshold limit value for a P2127 DTC would not be reached, and the VPA 0.4 Volt low threshold limit value for a P2122 DTC would not be reached. Signal interconnection through resistance could then potentially tie the two circuits together without setting a DTC. At that point, APP signal circuit redundancy is lost and neither signal circuit is verifiable by the ECM as defective. The ECM will only react to defective voltages outside of the range of programmed limitations-so if the circuit is not defective; it must be good. Without a DTC set, the ECM will not logically enter into a fail-safe mode of operation.

## **Vehicle Testing Methodology**

The Automotive Technology Department at Southern Illinois University Carbondale (SIUC) has a long history of teaching the technical aspects of vehicles. Working closely with the automotive industry, SIUC has the privileged position of receiving a considerable number of manufacturer donated vehicles for educational and research purposes only. The vehicles used in this research study were purposely selected from the SIUC fleet because of the experimental nature of the testing methodology. As a standard safety and liability requirement of manufacturer vehicle donations, all vehicles used for educational training cannot be licensed, titled, or driven on a public roadway. In addition, when the useful life of the vehicle is exhausted they are destroyed. The SIUC fleet vehicles were clearly a most valuable asset to ensure the safety and control limitations of this unique study.

Test vehicles selected for use in this study were required to meet certain predetermined technical and mechanical requirements. Since ETC was the major emphasis of this investigation, all SIUC vehicles *not* equipped with electronic throttles

were logically excluded. Fortunately, the SIUC fleet had four Toyota manufactured ETC vehicles that could be included for testing. Since engine displacement and number of cylinders is not a determining factor in basic ETC operation, vehicles with different engine sizes and configurations were included. Prior to ETC testing procedures, all vehicles used in the study were checked for proper engine performance, electrical system operation, and absence of existing DTC's. Vehicle problems or servicing needs were repaired as necessary before initiating ETC testing procedures.

For each of the test vehicles, ETC specific technical service information was well researched. Collected service information included (but was not limited to) basic ETC operational characteristics, wiring diagrams, electrical connector pin designations, component descriptions, DTC repair procedures, and fail-safe mode criteria. The primary information source for Toyota vehicles was the Technical Information System (TIS), which provides service support for all Toyota produced vehicles in the United States. To ensure technical accuracy before and during testing procedures, hard copies of vehicle service information were printed for laboratory use as needed.

Instruments and test equipment used in this study were typical of those used by automotive service professionals. Tools utilized for circuit testing and evaluation included; Fluke 88 digital multi-meters, Pico Automotive Oscilloscopes, IET decade resistance substituters (variable resistance boxes), connector back-probing devices, and common jumper wires. The high impedance Fluke 88 digital multi-meter was used for testing circuit resistance, grounded circuits, short circuits to power, and shorts between circuits. For purposes of observing and evaluating ETC operational characteristics, a laptop computer based Pico four channel Automotive Oscilloscope was utilized to display and capture waveforms. Simple varying resistance boxes were used to simulate poor circuit connections, short circuits, and mimic defective sensor inputs. Generic OBD II and manufacturer specific scan tools were used to identify the types of DTC's and view the ECM data values for sensor inputs and actuator outputs. Because of availability and versatility to work with many different makes and models of vehicles, the Actron AutoScanner Plus scan tool was used extensively to read DTC's, erase DTC's, and view generic OBD II data during testing.

The first step in the research process was the validation of normal operation of the ETC system in each of the selected test vehicles. Establishment of a solid baseline of proper operation was imperative to evaluate changes in the ETC systems due to the direct effects of testing. As a preconditioning requirement to prevent high idle from cold start-up, each engine was started and allowed to reach normal operating temperature before initiating testing methods. General overall engine performance and condition was noted. Scan tools were used to verify the proper operation of the vehicle's MIL and the ECM's capability to detect and record DTCs. Normal scan tool information, scope patterns, and voltage parameters were observed and recorded for all test vehicles used in the study. In addition, general notations were made of the engine speed and response rate with accelerator pedal depression. Engine response was observed during both: accelerator pedal depression with brake pedal released, and accelerator pedal depression with the brake pedal depressed.

Using the vehicle service information as a guide, APP connectors were initially back-probed to tap into the supply, signal, and ground circuits of the sensor. Voltmeter readings were used to verify the circuit integrity of the test connections. Once a solid connection to the circuit was verified, the oscilloscope was connected to visually monitor voltage changes in the APP circuits. Starting from this point, potential types of circuit abnormalities and experimental combinations were examined. Following the fail-safe monitor strategies and the typical malfunction thresholds from the Toyota TIS service literature, DTC detection conditions were painstakingly examined and tested for validity (Appendix: TIS Document).

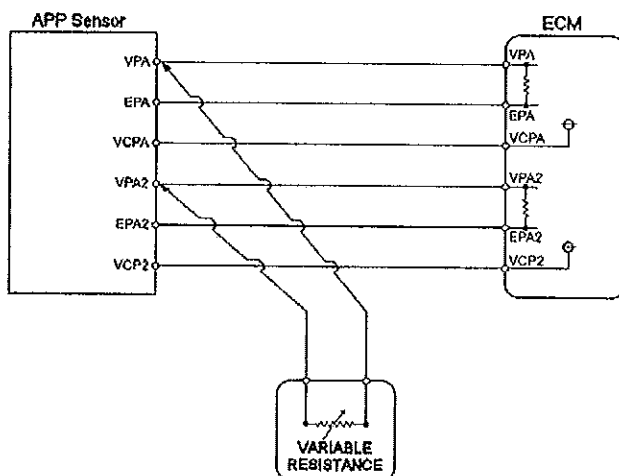

Validation testing began with DTC P2138, which is intended to detect abnormal conditions concerning the APP sensor, the ECM, and short circuits between VPA and VPA2 circuits. While monitoring APP signal voltages with the ignition “Key ON-Engine OFF” (KOEO), various resistances between the two APP signal circuits were introduced for trial. The effects of the different resistance values were recorded to determine the ECM’s actual circuit detection capabilities for this type of circuit malfunction. Ample time duration of “2.0 seconds or more” was allowed, as listed in the service literature for one trip detection logic. MIL illumination was used to signal the presence of ECM fault detection and subsequent DTC storage. It was soon realized that certain short circuit resistances between VPA and VPA2 were undetectable by the ECM. Once initial fault limitations were roughly established, “Key ON-Engine Running”(KOER) trials were conducted with similar fault detection procedures. Of particular interest was vehicle engine operation within the ECM acceptable voltage zone of a compromised VPA to VPA2 circuit short. The test vehicles generally ran well, in spite of the simulated signal circuit malfunction.

While running the engine in a VPA to VPA2 short circuit state, without MIL illumination or stored DTCs, accelerator pedal response rate and range was noted. Accelerator pedal observations were made with simultaneous brake pedal application, and without simultaneous brake pedal application. Recorded data, observations, and results were listed in detail for each specific test vehicle. To further test the absence of fault detection, experimentation was done to determine if the ECM would set a DTC with a combination of additional circuit abnormalities. Two combination tests were performed to include VPA and VPA2 shorted together (operating undetected), and circuit continuity to ground and power. The VPA and VPA2 signals operating in a short circuit state (undetected by the ECM)

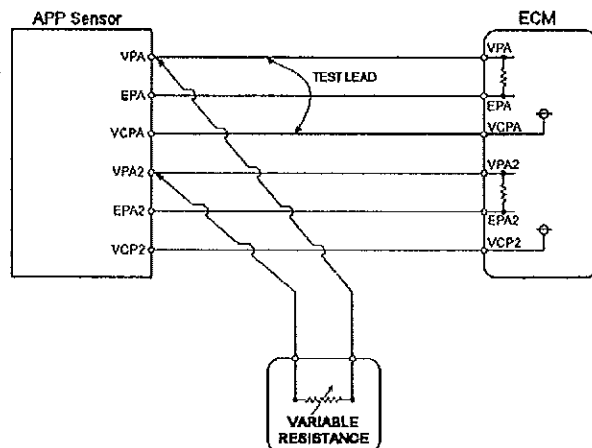

were given a circuit path to EPA AND EPA2 (ground). Additionally, the shorted VPA and VPA2 signal circuits (undetected by the ECM) were tested with a circuit path to the VCPA and VCP2 (5 Volt supply). These tests were made during both: KOEO, and KOER conditions. Several different combinations of trials were made before discovering that when VPA and VPA2 were shorted together, with an undetectable resistance, and a connection was made from either VCPA or VCP2 to the VPA2 circuit *only* – both VPA voltages would rise together in unison. As a direct result of the connection to the VCP 5 volt supply circuit, the ECM responded by opening the engine’s throttle. Surprisingly, the ECM was repeatedly unable to detect this serious circuit fault abnormality. The vehicle showed no MIL illumination nor stored DTC in the ECM. Most alarming during KOER trials, the engine speed increased almost instantaneously to the full operating RPM limits of the engine. The resulting condition was also present with or without brake pedal application.

At this point, the back-probing of the APP circuits and ETC testing procedures were re-evaluated. All Toyota test vehicles were considered operationally unstable, with the known potential to reach Wide Open Throttle (WOT) anytime after the engine was started. For more extensive investigation on the research vehicles, wire test leads were tapped directly into the APP wiring harness. The decisive reasoning for installing wire taps was to provide more secure and

stable connections to the APP circuitry. By providing more accessible and manageable “pin-out” connections of the APP circuits, testing methods were enhanced with more reliable voltage and resistance measurements. Plus, secure and clearly labeled circuit connections

provided for a much safer laboratory testing environment. Evaluation tests were now more narrowly focused on the capabilities of the ECM to detect fault conditions to set a DTC P2138. DTC P2138 is the code used to detect the presence of a short between VPA and VPA2 signal circuits. Resistance values for shorted VPA and VPA2 signal circuits,

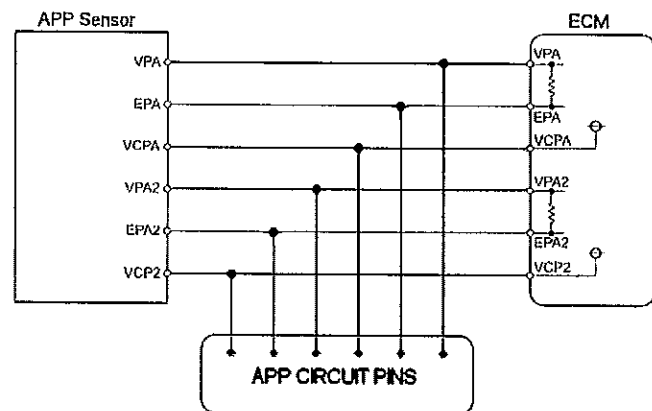

in combination with a short to the VCP 5 Volt supply circuit, were examined and recorded for threshold parameters. In addition, vehicles were tested to see if these shorted signal circuit conditions and WOT, could be active while the vehicle transmission was in drive and service brakes applied and released. For obvious safety reasons, these more extreme tests were performed outside the laboratory in an uninhabited open parking area.

## **Summary**

After completing preliminary tests for APP sensor signal voltages for the Toyota Electronic Throttle System, it was determined that ECM malfunction detection strategies were not sufficient to identify all types of fundamental APP sensor and/or circuit malfunctions. Some types of ETC circuit malfunctions were detectable by the ECM, and some were not. Most importantly, the Toyota detection strategies were unable to identify malfunctions of the APP sensor signal inputs to the ECM. APP sensor signal circuits must be undeniably correct to electrically convey the appropriate driver commands to the ECM.

With the two APP sensor signals shorted together through a varying range of resistances, all four Toyota vehicles reacted similarly and were unable to detect the purposely induced abnormality. The types of signal faults introduced into the APP circuit should have triggered the vehicles' ECM to illuminate a MIL within seconds. The ECM should have then set a DTC, entered the vehicle "fail-safe" mode, and reduced engine speed and/or power. When the two APP signal circuits are shorted together, the redundancy of the APP circuit design is effectively nullified and lost. In other words, neither of the shorted APP signal circuits can be verified by the ECM as either; correct or incorrect. The condition then exists for a serious concern for driver safety. In the tested Toyota ETC vehicles, incorrect or corrupted APP sensor signal inputs could potentially result in unwanted engine speeds. Additional research should be done to determine if other vehicle manufacturers may have similar inconsistencies in ETC circuit fault detection.

Using shorted APP signal circuit fault conditions purposely installed on the test vehicles, and with known resistance values that would not set a DTC, vehicle operational behaviors were also noted. It was observed that all test vehicles could be operated without the ECM detecting the induced malfunction. Depending on the resistance value of the APP signal circuit fault, a vehicle may or *may not* experience noticeable changes in accelerator pedal operational behavior. Observed accelerator pedal operational characteristics included: normal response, sluggish response, and travel with inconsistent engine speeds. It is conceivable that a driver of an ETC vehicle may not appreciatively notice that an APP sensor and/or circuit malfunction currently exists. Without the aid of an illuminated MIL, a driver could be unaware of electrical problems within the ETC system. In addition, the shorted APP signal circuits were connected momentarily to the sensor's 5 Volt supply circuit with the vehicle in drive. In all test vehicles, the ECM did not set a DTC and the engine speed increased rapidly to full throttle. This result shows that unusual or sudden unintended acceleration of the vehicle was possible in the ETC test vehicles. It should be noted that in all test vehicle cases, the electronic throttle valve *instantaneously* moved to wide-open position when the fault was introduced. More research should be done to determine the extent of Toyota ETC vehicles that could be affected by this condition.

In review of the TIS service information, collected vehicle data, and performance observations; some general assumptions can be drawn from the research completed to date. The inability of the Toyota ECM to detect certain types of short circuit malfunctions could fall back to the basic design of the normal APP signal voltage limitations. The parameters for APP signal short circuit fault detection are apparently too lenient. In the Toyota ETC system, the APP sensor signal voltages rise simultaneously in direct response to accelerator pedal depression. With this design, interconnected signal circuits could be more difficult to identify with a circuit fault detection strategy that uses only threshold voltage limitations.

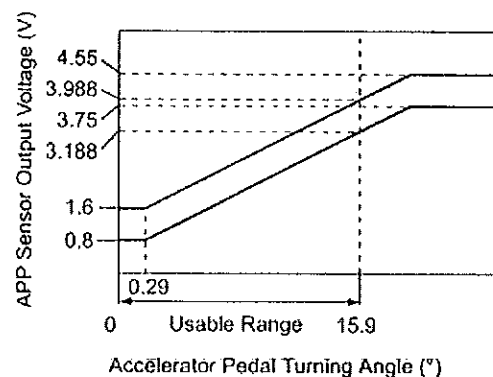

A more conclusive circuit fault detection strategy could use APP signal voltages (see A & B) that have rising slope, but with offset voltages that increase at slightly different rates. Several vehicle manufacturers currently use this fault detection strategy for APP sensor signal circuits.

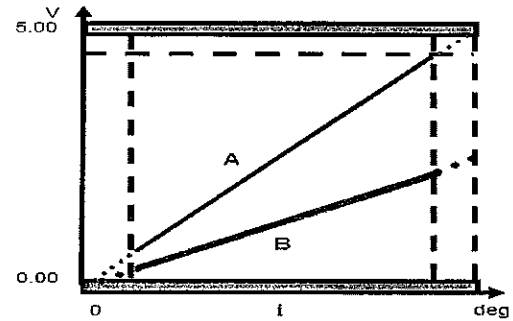

The obvious advantage, of using two different angles of increasing voltages from the APP signal circuits, is that the signal voltages are never consistently rising at the same rate. In this design, short circuit connections between the two APP signal circuits would ultimately be detected by the ECM because the signal voltages should never increase at the same rate or angle.

## Recommendations

In this preliminary report, the initial findings question the integrity and consistency of Toyota ECMs to detect potential ETC system circuit malfunctions. The importance of these issues raised in the ETC system fail-safe strategies should not be underestimated. Sudden unintended acceleration of a vehicle is a very serious safety concern that should be addressed without delay. While the small sample of Toyota vehicles cannot be representative of all, these primary findings most certainly warrant further investigation and study. Additional Toyota vehicles of different build years and models should be evaluated for their capabilities of ETC system circuit malfunction detection.

A second recommendation should be a thorough technical investigation and evaluation of ETC fail-safe strategies of Toyota, and possibly other vehicle manufacturers, that experience sudden unintended acceleration that do not appear to be caused by floor-mats or sticking pedals. Priority would be studies of identified vehicles with a high rate of ETC system related incidences, concerns, or failures involving sudden unintended acceleration.

## Appendices

### Toyota Electronic Throttle Control Investigation Vehicles

---

- 1) 2005 Toyota Avalon (4T1BK36B55U001024)
- 2) 2006 Lexus IS350 (JTHBE262762001849)
- 3) 2007 Toyota Tundra (5TBBV54177S449783)
- 4) 2009 Toyota Matrix (2T1GE40E19C001003)

**Additional Appendices and supporting data will be provided when completed.**